

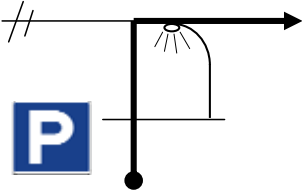
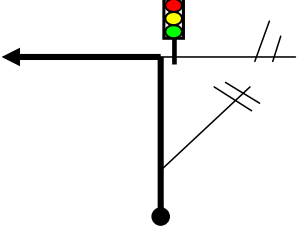
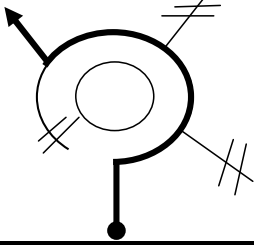

I ARRATIAKO RALLYE

CALIBRACIÓN

Nº	DIST . TOTAL	DIST . PARCIAL	DIRECCION	INFORMACION
1	0,000	0,00		LOCAL  FAROLA
2	0,103	0,10		LOCAL x BI-3527
3	1,606	1,50		BI-3527
4	1,810	0,20		BI-3527 x N-240
5	3,673	1,86		N-240 x BI-3530 ARTEA AREATZA <del>VITORIA</del> <del>GASTEIZ</del>
6	3,836	0,16		BI-3530 ARTEA AREATZA <del>BILBO</del>

I ARRATIAKO RALLYE

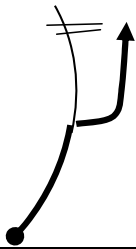
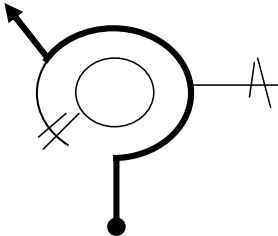
CALIBRACIÓN

Nº	DIST . TOTAL	DIST . PARCIAL	DIRECCION	INFORMACION
----	-----------------	-------------------	-----------	-------------

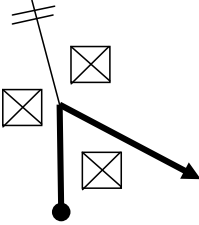
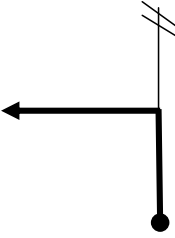
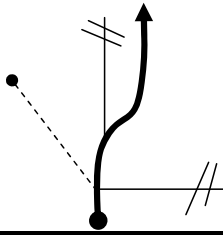
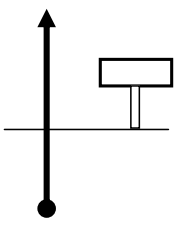
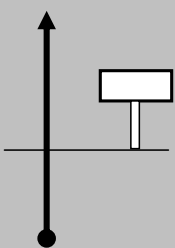
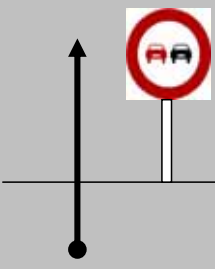

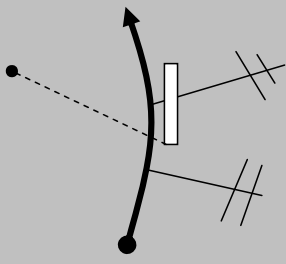
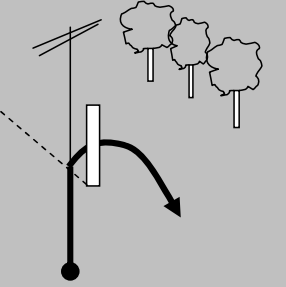
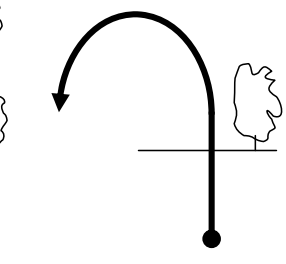
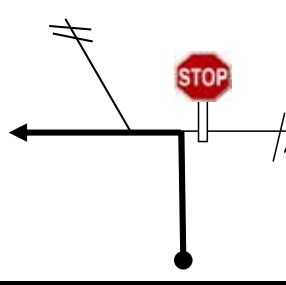
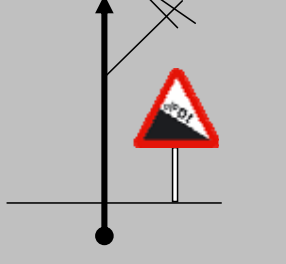
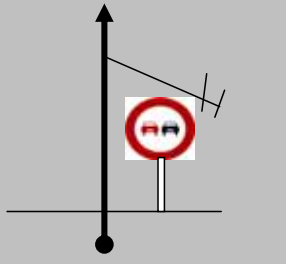

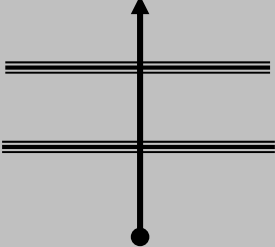
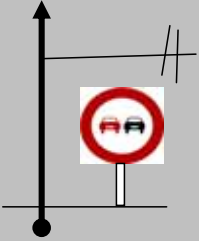
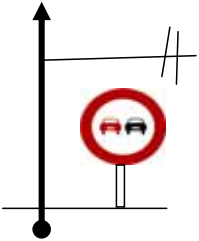
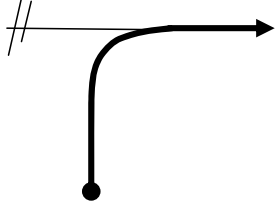
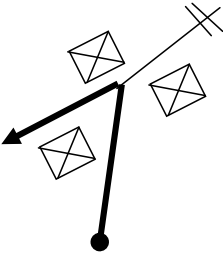
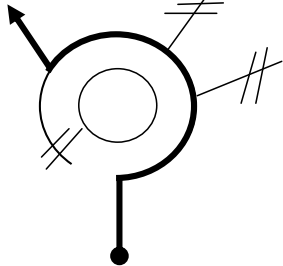

7	4,143	0,31		BI-3530 x BI-3524 7 ZEBERIO UGAO 13 MIRAVALLS OROZKO 15
8	4,736	0,59		BI-3524 x BI-3513 OROZKO
9	4,815	0,08		BI-3513 <del>GALLAO</del> <del>MADARIAGA</del>
10	4,843	0,03		BI-3513 ← ELEXABEITI
11	0,000	0,000		BI-3513 ← ELEXABEITI
12	2,523	2,523		BI-3513 SEÑAL DE PROHIBIDO ADELANTAR AL REVES

I ARRATIAKO RALLYE				
CALIBRACIÓN				
Nº	DIST . TOTAL	DIST . PARCIAL	DIRECCION	INFORMACION
13	2,960	0,437		BI-3513
				POSTE INDICATIVO DE MADERA
14	4,884	1,924		BI-3513 x LOCAL
				FIN DE CALIBRADO POSTE METALICO
15	4,942	0,06		LOCAL
				MATORRAL
16	5,037	0,09		LOCAL x BI-3513
17	0,000	0,000		BI-3513
				INICIO DE CALIBRADO SEÑAL DE 12 % DESCENSO
18	2,109	2,109		BI-3513

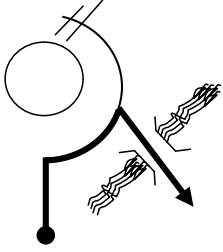
I ARRATIAKO RALLYE				
CALIBRACIÓN				
Nº	DIST. TOTAL	DIST. PARCIAL	DIRECCION	INFORMACION
19	3,774	1,665		BI-3513
				2º PILAR PASO ELEVADO CONSORCIO DE AGUAS
20	4,848	1,074		BI-3513
				FIN DE CALIBRADO SEÑAL DE PROHIBIDO ADELANTAR
21	0,000	0,00		BI-3513
22	0,134	0,13		BI-3513 x BI-3524
23	0,717	0,58		BI-3524 x BI-3530
24	0,987	0,27		BI-3530
				<del>VITORIA GASTEIZ</del> BILBO

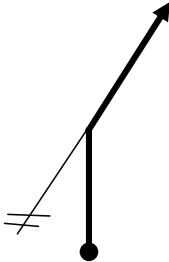
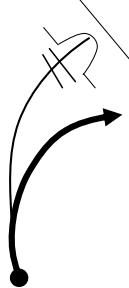
I ARRATIAKO RALLYE

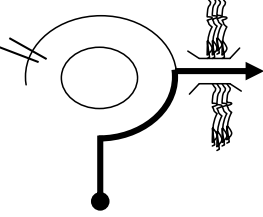
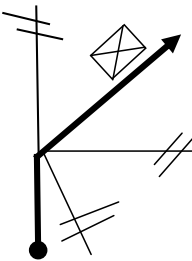
CALIBRACIÓN

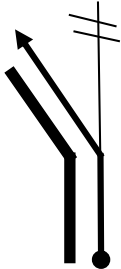
Nº	DIST . TOTAL	DIST . PARCIAL	DIRECCION	INFORMACION
25	1,411	0,42		BI-3530 x N-240
				
26	1,590	0,18		N-240
27	3,265	1,68		N-240 x BI-3527
				 
28	3,521	0,26		BI-3527
29	3,677	0,16		BI-3527 x LOCAL
				
30	4,855	1,18		LOCAL

I ARRATIAKO RALLYE

CALIBRACIÓN

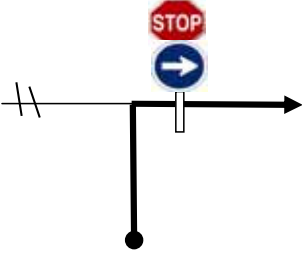
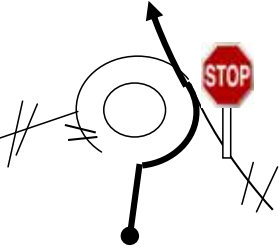
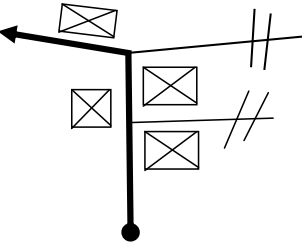
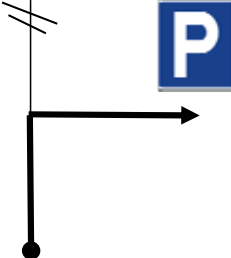
Nº	DIST . TOTAL	DIST . PARCIAL	DIRECCION	INFORMACION
31	4,968	0,11		LOCAL
32	5,064	0,10		LOCAL x BI-2543
33	5,289	0,23		BI-2543
34	5,427	0,14		BI-2543 x LOCAL